

Lee R. Sharpe. (b. 1960) Associate Professor. B.A., 1983, Ripon College; Ph.D., 1987, University of Wisconsin - Madison; Postdoctoral Fellow, 1987-1989, University of Cincinnati; Visiting Assistant Professor, 1995-1996, University of North Carolina - Chapel Hill; Visiting Research Fellow, University of Oregon, 2003. ANALYTICAL CHEMISTRY. Semiconductor based Chemical Sensors, and CE of inorganic ions. (641) 269-3008. sharpe@grinnell.edu

Introduction

Our research involves the study and testing of a variety of semiconductor materials for the development of powdered phosphor-based chemical sensors and the development of catalysts for the photoelectrolysis of water. The second project is new and will depend on a pending grant proposal. Both areas of research are of national interest. The need for better environmental monitoring and sensing chemical agents requires the development of better and more selective chemical sensors. The development of a hydrogen economy requires an efficient, sustainable method of producing hydrogen. A third unrelated project concerns the development of a field CE instrument with high sensitivity.

Chemical Sensor Project

Our sensors indicate the presence of a gas by changes in the photoluminescence, PL, intensity relative to nitrogen as a reference gas. We have been exploring a variety of powdered semiconductor phosphors primarily developed in the 1960's and early 1970's for use in lighting and colored television as candidates for optically coupled chemical sensors. Powdered phosphors are relatively easy to prepare, stable, brightly emissive, and appear to be highly selective as chemical sensors. As a result, sensors can be developed that do not consist of single-crystal components or colloids and do not require laser excitation. In addition, a wide variety of chemically different phosphors with different impurities (added to increase the fluorescence) can be investigated in an effort to understand how the chemical make-up of the surface affects the sensor response. Our hope is the development of a family of chemical sensors based on these powdered phosphors that have both good sensitivity and complementary selectivity so that they may be used in gas sensor arrays. In the few powdered phosphors that we have investigated, we have found a significant difference in the response of the different phosphors to different gases. In addition, studying changes in PL upon exposure to various substances provides a novel means to explore the surface chemistry at the solid/gas interface.

Our work demonstrates that sensors based on the PL of semiconductor materials can be developed that are highly selective toward certain compounds and the selectivity can be varied by changing the composition of the semiconductor.

Completed Work and Findings: Our original success with this project was centered on the powdered tellurium doped CdS phosphor, pCdS:Te.^{1,2} and later CaS³ based phosphors in addition to SrS, ZnS and more recently ZnO and ZnSiO₄ based phosphors. pCdS:Te is easily prepared and is brightly emissive having a emission maximum of 670 nm (red-orange in color). When exposed to sulfur dioxide, there is a distinct decrease in the PL intensity as shown in figure 1a. The wavelength of the emission does not change, just the PL intensity. On the left side is the PL spectrum of the pCdS:Te under a nitrogen atmosphere and then moving off to the right is the PL intensity at 670 nm resulting from alternating the exposure between nitrogen and various concentrations of sulfur dioxide. The PL response is both reversible and reproducible and the magnitude of the PL change is dependent on the concentration of the sulfur dioxide. Figure 1b shows how pCdS:Te responds to ammonia. Again the PL response is both

reversible and reproducible and the magnitude of the PL change is dependent on the concentration of ammonia. In this case, however, the PL increases upon exposure to ammonia as opposed to decreasing under sulfur dioxide exposure. Exposure to 100% ammonia produces an interesting spike.

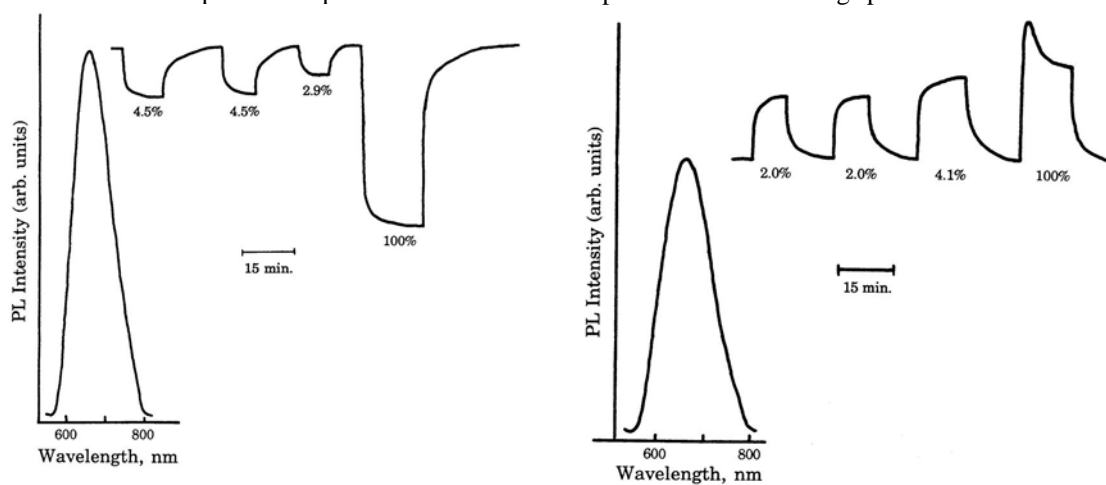

Figure 1 a) Exposure to sulfur dioxide

b) Exposure to ammonia

Explanation of the Effect The variation in the PL intensity of pCdS:Te is caused by the interaction of the adsorbed gas with the phosphor. pCdS:Te is a n-type semiconductor. In the near surface region of the pCdS:Te particles, there is an electric field created by the equilibration of the pCdS:Te Fermi level with surface states which are created by dangling bonds (a result of the truncation of the lattice), elemental vacancies, and impurities in the near surface region. Electrons flow out from the pCdS:Te to these surface states thus depleting the pCdS:Te of electrons and producing an electric field at the surface. When the phosphor is exposed to the Lewis base ammonia, the ammonia adsorbs onto the surface and donates electron density to the pCdS:Te causing the electronic field to be reduced relative to the field under nitrogen. The opposite process occurs when the phosphor is exposed to the Lewis acid sulfur dioxide which accepts electron density from the phosphor thus increasing the electric field. The PL intensity changes as a result of the interrelationship between the size of the electric field in the near surface region and the PL intensity. This interrelationship is explained by the Dead Layer model.⁴

Langmuir adsorption isotherm model The PL response for the pCdS:Te phosphor is concentration/pressure dependent so it should be able to be modeled by the Langmuir adsorption isotherm model. In 1918 Langmuir⁵ developed equations that model the relationship between gas pressure and the amount of adsorbed gas on the surface of a solid. This model has been successfully used to model adsorption on a variety of semiconductor surfaces. In the simplest case, Langmuir assumed: (1) that the surface of the solid contains a fixed number of adsorption sites; (2) at any temperature and gas pressure, a fraction of the sites are occupied at equilibrium; (3) each site can only hold one adsorbed molecule (4) each site has the same tendency to absorb a gas molecule (5) there is no interaction between one adsorbed molecule and another; (6) and only one monolayer can be adsorbed. From this the following equation can be derived:

$$1/\theta = 1 + 1/KP_A$$

A plot of $1/\theta$ vs. $1/P_A$ will give a linear plot with a slope of $1/K$ and an intercept of 1.

Figure 2a and 2b show how the fractional surface coverage on pCdS:Te varies with the partial pressure of sulfur dioxide and ammonia respectfully. At low partial pressure the data in both plots appears to follow

typical Langmuir behavior; however, at higher partial pressures (above ~0.2 atm) there appears to be a step in which the data no longer follows Langmuir behavior. This step is reproducible and appears independent of whether one starts at high or low gas pressure. Plots of $1/\theta$ vs. $1/P_A$ for the data points just below 0.2 atm, shown in the insets of figures 2a and 2b, yield linear plots for both gases, indicating that Langmuir's assumptions hold. In both plots the first points were omitted due to what we believe to be our inability to reproducibly control the gas concentration at low flowrates.

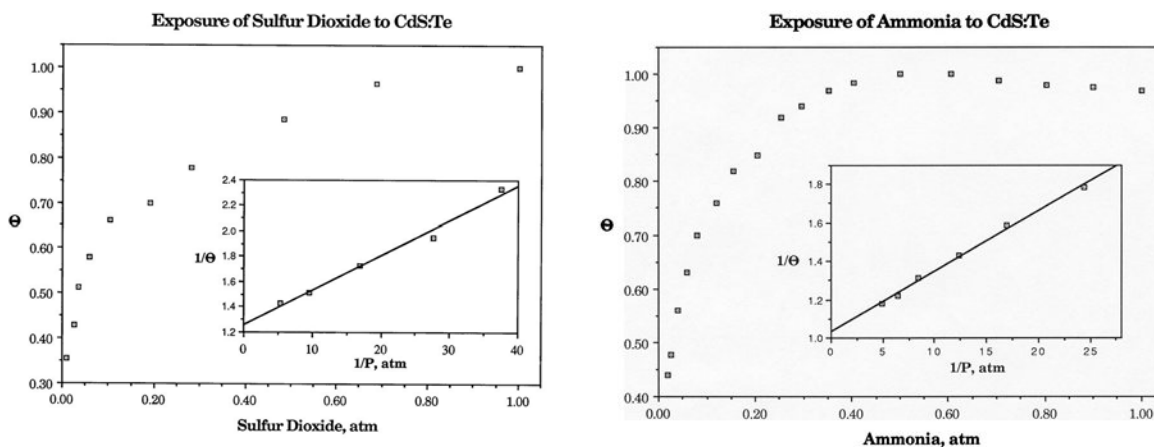

Figure 2 Fractional surface coverage on CdS:Te as a function of the partial pressure of a) sulfur dioxide and b) ammonia

Photoelectrolysis of Water Project

This project is very much a search for the "Holy Grail." Looking through a wide range of mixed metal oxides for one that can use sunlight to convert water to hydrogen and oxygen. Over 30 years ago TiO_2 electrodes produced hydrogen from water without decomposition under UV illumination. The problem is that the absorption of light by TiO_2 does not overlap well with the solar spectrum. This is a combinatorial project. We will be involved with several groups around the nation testing a range of mixed metal oxide compounds to identify ones that can oxidize water to oxygen and others that can reduce water to hydrogen. In effect we are looking for two "Holy Grails." The idea is to use two different materials having smaller band gaps than TiO_2 and thus make better use of the solar spectrum.

The experiment will involve the deposition of metal ion solutions onto conductive glass substrates using a Lego Mindstorms® kit and a new DeskJet like printer cartridge. The films are then dried and fired at 500°C for 24 hours in air to form the oxides. The resulting films are tested as electrodes under illumination to see if they demonstrate any photocatalytic behavior. This unique system has the ability to vary the composition of the metal oxide films over the electrode surface thus allowing multiple compositions to be tested on one electrode. We can also test these new materials as chemical sensors.

Capillary electrophoresis (CE) Project

CE is the migration of different ions under an applied electric field in a capillary. Ions are separated by how fast they move through the capillary. A home built CE system was assembled a couple years ago and is diagramed below.

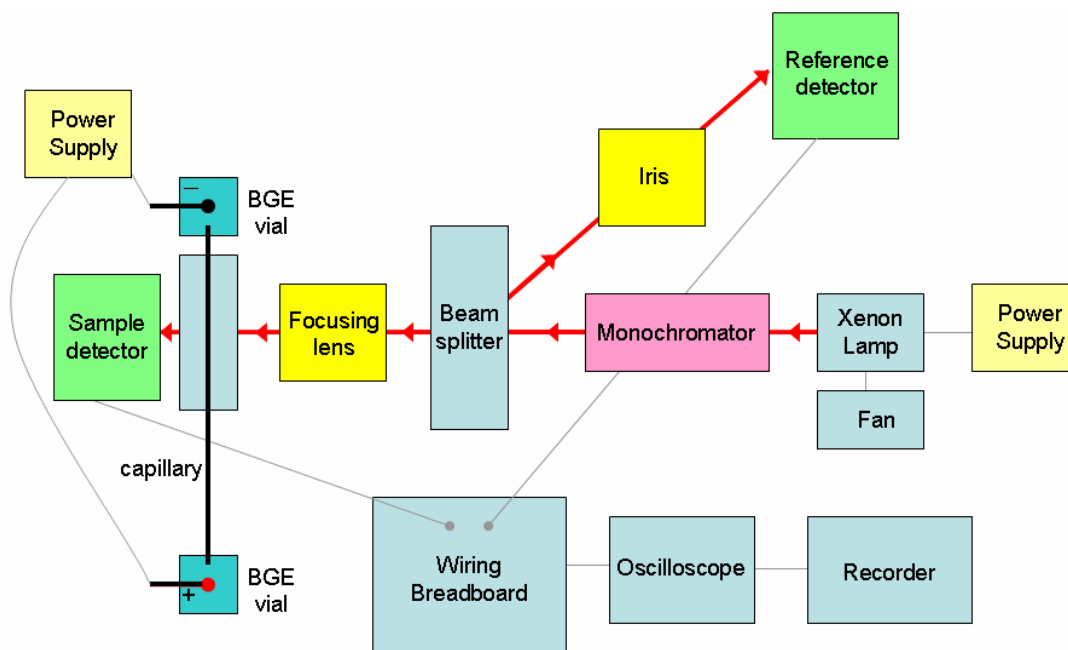

The system performed as well as those reported in the literature for the analysis of inorganic anions such as chloride. The next step is to replace the xenon lamp and monochromator with a simple LED that has the correct output frequency to overlap with the absorption of the chromate ion that is used for indirect detection as shown below.

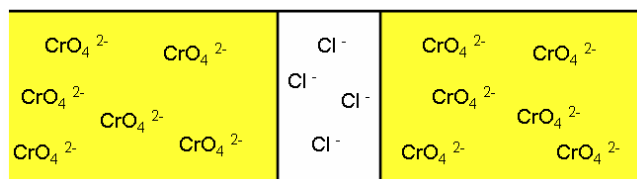

The colorless analyte ion, chloride, displaces the chromate in the capillary thus giving a reduction in the absorbance that indicates its presence.

One of the things that degrades the detection limit is the noise of the light source. A xenon source is very noisy compared to a battery operated LED. In addition, the elimination of the light source and monochromator significantly reduces the size and weight of the instrument thus making it possible to construct a lightweight instrument for field water analysis.

Projects:

1. Continue development of sensors that are composed of chemically different phosphor materials specifically $\text{ZnSiO}_4:\text{Mn}$.
2. Test and use a developed Sol Gel method to immobilize the phosphor powders. Next test ZnO phosphors to explore the effect temperature has on the adsorption of gas molecules on these phosphor materials to see if these materials will function as high temperature sensors.
3. Start the Photoelectrolysis of Water Project

4. Substitute a LED light source into the home built CE system to analyze anions by indirect detection using chromate.

References

1. Patel, M.; Langsdorf, B.; Sharpe, L.R. *SPIE Proc.* **1994**, Vol. 2293, p. 156-166.
2. Patel, M.; Pu, C.J.; Sharpe, L.R., *Langmuir* **1995**, 11, 2003-2008.
3. CaS paper in preparation
4. Hobson, W.S.; Ellis, A.B. *J. Appl. Phys.* **1983**, 54, 5956.
5. Langmuir, I. *J. Am. Chem. Soc.* **1918**, 40, 1361.

